

M9601A PXIe Precision Source/Measure Unit, 1.25 MSa/s, 10 fA, 210 V, 315 mA

Industry high-performance PXIe SMU enabling faster precise dynamic measurement from DC to 20 μ s pulse with lowest source noise

Introduction

The Keysight M9601A is a PXIe precision source/measure unit (SMU). It covers currents from 10 fA to 315 mA and voltage from 500 nV to 210 V and can make DC measurements to pulsed measurements with 20 μ s pulse width, with a sampling rate up to 1.25 MSa/s. That makes the M9601A ideal for a variety of current versus voltage measurement tasks that require high resolution and accuracy, such as semiconductor test, active / passive component test, and general electronic device.

This guide provides step-by-step instructions to help you configure an SMU and its related accessories to meet specific test requirements. For detailed specifications, refer to the M9601A PXIe precision SMU data sheet (publication number 5992-4192EN).

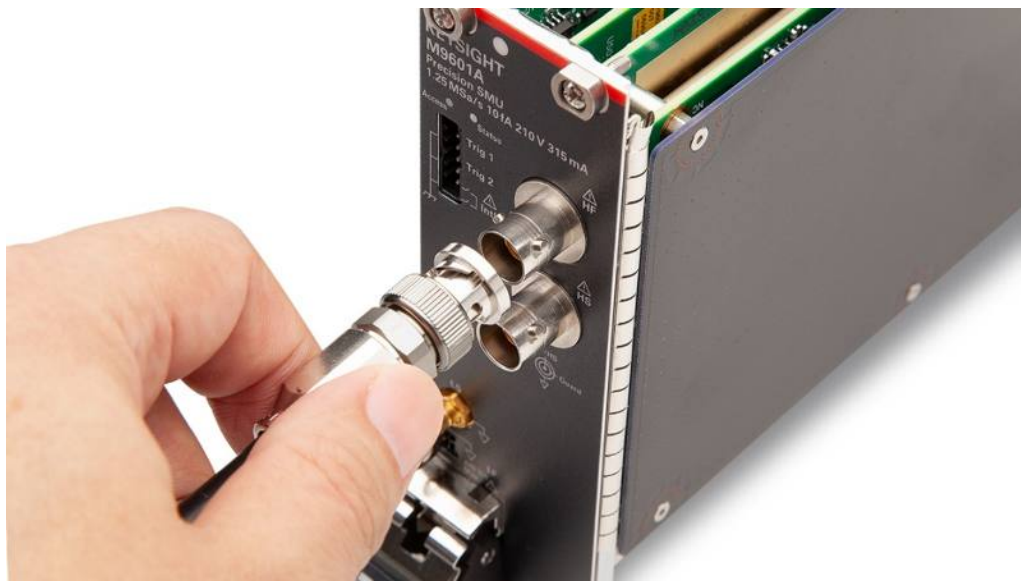

Configure Your Keysight M9601A Precision SMU

Step 1. Define the required number of M9601A modules

The M9601A PXIe precision SMU occupies two slots in the PXIe chassis. You need to define the required number of modules based on your application requirements.

Product number	Required slots	Number of channels	Max output	Min resolution	Max sampling rate
M9601A	2	1	210 V 315 mA	500 nV 10 fA	1.25 MSa/s



The following items come standard with each M9601A PXIe precision SMU module:

Description	Qty.	Additional information
Quick startup poster	1ea	Printed reference for quick startup (English)
Certificate of calibration (without test data)	1ea	Certificate of calibration (without actual test data). If you need the test data, please specify option UK6.
Short bar	1ea	Short bar to connect low terminals to chassis common; orderable part number is M9601-87001 (includes 5 qty.)
Connector-terminal block 2.5 mm 6-terminal	1ea	Connector-terminal block to connect external trigger terminals and interlock terminal; orderable part number is M9601-87002 (includes 5 qty.)

Step 2. Select optional accessories for each module

Step 2-1. Determine if you need to make low terminals grounded

The low terminals of the M9601A are a floating configuration, enabling you to connect them to any potential up to ± 40 V. If your device-under-test interface is floating and you need to make the M9601A's low terminals grounded, you may do so by attaching a short bar, as shown in Figure 1. The M9601A ships with the short bar attached.

Attach a short bar to make low terminals grounded

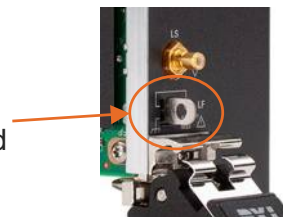

Figure 1. A short bar makes the M9601A's low terminals grounded

Step 2-2. Determine whether you need to make four-wire measurements

The M9601A supports both two-wire and four-wire measurement. The simpler two-wire configuration uses only the force terminals. In two-wire mode, the sense terminals remain open.

If you are measuring very small resistances or applying very large current, you should use the four-wire measurement method (also known as the Kelvin method). This technique uses both force and sense terminals. Making the measurement through the sense terminals (in which no current is flowing) eliminates the effects of cable resistance.

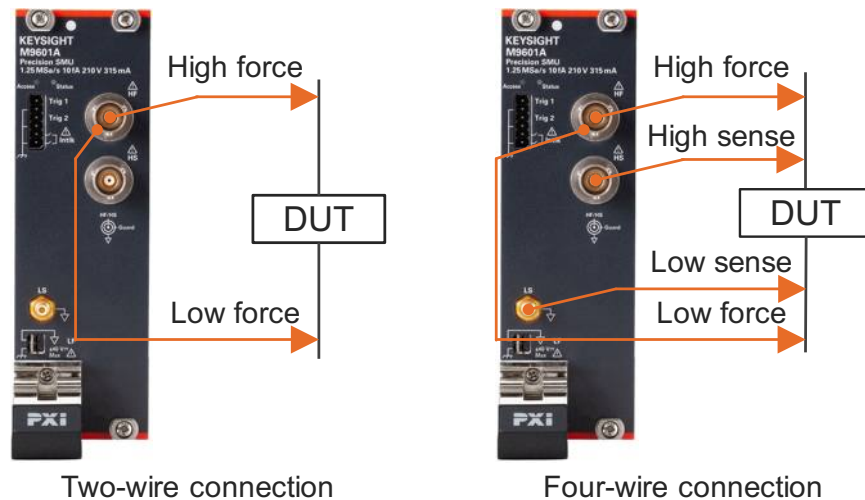

Figure 2. Two-wire connection and four-wire connection

Low current measurements ($< 1 \text{ nA}$) require guarding to prevent leakage through the measurement cable. Figure 3 provides a simplified overview of the guarding technique. Guarded measurements require the use of triaxial cables. A follower ($\times 1$) buffer amplifier keeps the guard conductor at the same potential as the center conductor. Since there is no voltage difference, no current can flow from the center conductor to the guard.

Note: in this example, even the device interface has a guarded shield to prevent leakage at the device interface.

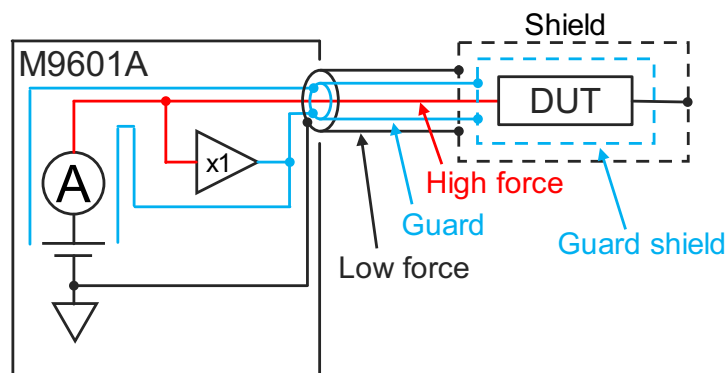

Figure 3. Guarding technique

1. Guarded two-wire connection scheme

	Floating connection		Grounded connection
Typical connection example			
Recommended accessories	PX0102A-001	1ea	Low noise triaxial cable, 1.5 m

2. Guarded four-wire connection scheme

	Floating connection		Grounded connection
Typical connection example			
Recommended accessories	PX0102A-001	2ea	Low noise triaxial cable, 1.5 m
	PX0103A-001	1ea	Triaxial to SMB cable, 1.5 m

Step 2-3. Consider interlock circuit

The M9601A has a safety interlock to prevent accidental exposure to dangerously high voltages. It cannot source voltages greater than ± 42 V (or the specified voltage within ± 42 V) unless the interlock circuit is closed. You can engage the safety lock using interlock pins on the connector at the front panel. Normally, these pins are routed to a shielding box or test fixture that must be closed to complete the interlock circuit.

You can install an interlock circuit as shown in Figure 4. If your shielding box has the BNC connector for the interlock circuit, you can use the PX0101A-001 or 002 BNC to ferrule terminal cable with a connector-terminal block to connect the M9601A's interlock pins to it. For more detailed information, please refer to the Keysight M9601A Startup Guide.

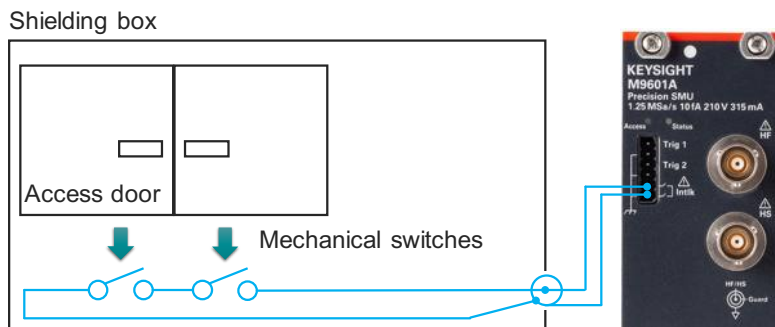

Figure 4. Example to install an interlock circuit

Step 2-4. Consider external trigger connection

Although the PXIe trigger lines in the chassis are available to synchronize the M9601A with the other PXIe modules, two external trigger lines are available if you need to synchronize it with the external instrument. You can use the PX0101A-001 or 002 BNC to ferrule terminal cable with a connector-terminal block to connect the M9601A's external trigger lines to the external instrument.

Step 3. Select additional accessories for each module

The following optional accessories are available for specialized requirements.

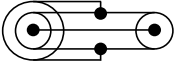
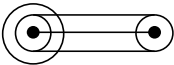
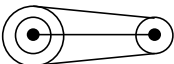
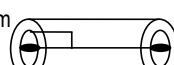
Description	Product number	Additional information
BNC to ferrule terminal cable, 1.5 m	PX0101A-001	Convert trigger or interlock terminals to BNC
BNC to ferrule terminal cable, 3 m	PX0101A-002	
Low noise triaxial cable, 1.5 m	PX0102A-001	Triaxial cable dedicated for M9601A
Low noise triaxial cable, 3 m	PX0102A-002	
Triaxial to SMB cable, 1.5 m	PX0103A-001	Convert low-sense terminal from SMB to triaxial
Triaxial to SMB cable, 3 m	PX0103A-002	
Triaxial(m) to BNC(f) adaptor	N1254A-101	
Triaxial(f) to BNC(m) adaptor	N1254A-102	
Triaxial(m) to BNC(f) adaptor	N1254A-103	
Triaxial(f) to BNC(m) adaptor	N1254A-104	
Triaxial(f) to BNC(m) adaptor	N1254A-105	
Triaxial(m) to BNC(f) adaptor	N1254A-106	
Triaxial(m) to triaxial(f) adaptor	N1254A-107	
Coax tee adapter(m-f-f)	1250-2405	
Triaxial tee adapter(f-m-f)	1250-1551	
Connector straight plug 6-pin circular	1252-1418	

Step 4. Select calibration plan

Step 4-1. Select the relevant calibration services (optional)

Factory calibration and certification of calibration come standard. The optional ISO 17025 (not accredited), ANSI Z540, and commercial calibration certificate with test data are available as follows:

Description	Product number	Additional information
Calibration + uncertainties + guardbanding (not accredited)	M9601A-1A7	Calibration certificate with measurement results available only at time of purchase
ANSI Z540-1-1994 calibration	M9601A-A6J	Calibration certificate with measurement results available only at time of purchase
Commercial calibration certificate with test data	M9601A-UK6	Calibration certificate with measurement results available only at time of purchase

Step 4-2. Select recalibration service plans (optional)

The following options are available. If you need other options — for example, the standard compliant calibration option — please contact your local Keysight office for availability.

Description	Product number
Calibration plan — return to Keysight — 3 years	R-50C-011-3
Calibration plan — return to Keysight — 5 years	R-50C-011-5

Related Literature

Publication number	Publication title
5992-4192EN	M9601A PXIe Precision Source/Measure Unit — Data Sheet
5992-0600EN	Keysight PXI and AXIe Products and Solutions — Catalog
5990-6379EN	Keysight PXI & AXIe Instruments, Software, Reference Solutions, and Services

Learn more at: www.keysight.com

For more information on Keysight Technologies' products, applications or services, please contact your local Keysight office. The complete list is available at: www.keysight.com/find/contactus

